

## FITTING INSTRUCTION

Clamp mark in acc. with		Cables joining
ISO	PN	
1	L	Left directional lights
2	+	Rear fog lights
3	31	Ground
4	R	Right directional lights
5	58R	Right side parking lights
6	54	Stoptlights
7	58L	Left side parking lights

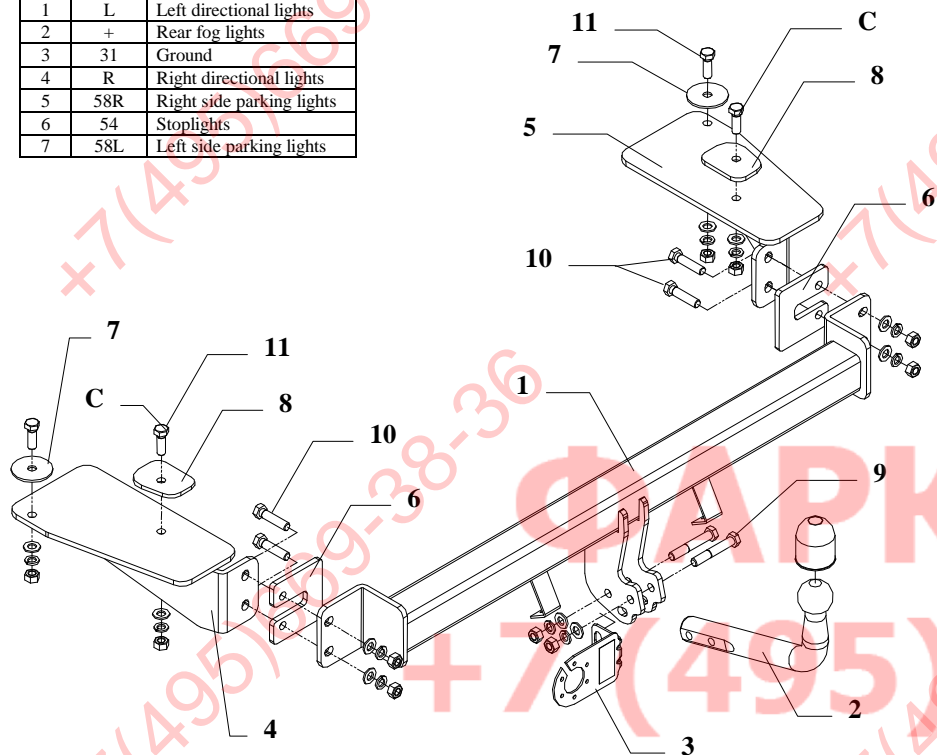

Fig. 1

This towbar is designed to assembly in following cars:  
**DAEWOO KALOS, 4 door**, produced since 09.2002, catalogue no. **X15**  
 and is prepared to tow trailers max total weight **1100 kg** and max vertical mass **75 kg**.

### From manufacturer

Thank you for buying our product. Their reliability has been confirmed in many tests. Reliability of towbar depends also on correct assembly and right operation. For this reasons we kindly ask to read carefully this instruction and apply to hints.

*The towbar should be install in points described by a car producer.*

## The instruction of the assembly

1. Disassemble a bumper and its inner fillings (not used any more).
2. Remove rubber plugs in pos. „C” (see drawing).
3. According to drawing fix loosely elements (pos. 4 and 5), use washers (pos. 7 and 8).
4. To rear part fix the main bar of the towbar (pos. 1) using elements (pos. 6), which should be placed between rear part of car and bar of towbar.
5. Fix bumper after cut out its fragment – see fig. 2.

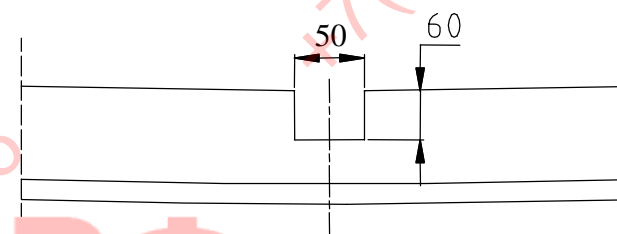

Fig. 2

6. Tighten all bolts according to the torque shown in the table.
7. Fix tow-ball (pos. 2) and socket plate (pos. 3) using bolts M12x75mm (pos. 9) supplied with towbar.
8. Connect electric wires of 7-poles socket according to the instruction of the car. (Recommend to make at authorized service station)
9. Complete the paint coating damaged during installation.

Torque settings for nuts and bolts (8,8):	
<b>M 8</b> - 25 Nm	<b>M 10</b> - 55 Nm
<b>M 12</b> - 85 Nm	<b>M 14</b> - 135 Nm









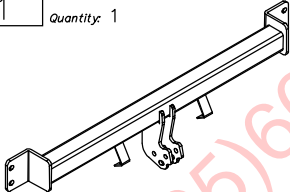
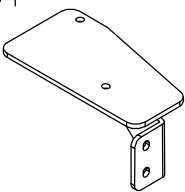
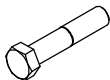

### NOTE

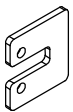
After install the towbar you should get adequate registration in registration book (at authorised service station).The car should be equipped with:

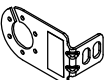
- Indicators
- Tow mirrors

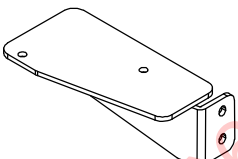
After 1000km of exploitation check all bolts and nuts. The ball of towbar must be always kept clean and conserve with a grease.

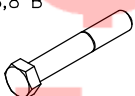
Towbar accessories:

Pos. 1	Name: Main bar Quantity: 1	Pos. 5	Name: Right bracket Quantity: 1	Pos. 10	Name: Bolt 8,8 B Quantity: 4 Dim.: M12x50mm
					
				Pos. 11	Name: Bolt 8,8 B Quantity: 4 Dim.: M12x35mm
					
Pos. 2	Name: Tow-ball Quantity: 1	Pos. 6	Name: Fish-plate Quantity: 1	Pos. 12	Name: Nut 8 B Quantity: 10 Dim.: M12
					
Pos. 3	Name: Socket plate Quantity: 1	Pos. 7	Name: Round washer Quantity: 2 Dim.: Ø58xØ13x3mm	Pos. 13	Name: Plain washer Quantity: 10 Dim.: Ø 13 mm
					
Pos. 4	Name: Left bracket Quantity: 1	Pos. 8	Name: Washer Quantity: 2	Pos. 14	Name: Spring washer Quantity: 10 Dim.: Ø 12,2 mm
					
		Pos. 9	Name: Bolt 8,8 B Quantity: 2 Dim.: M12x75mm	Pos. 15	Name: Ball cover Quantity: 1
					



PPUH AUTO-HAK S.J.

Produkcja Zaczepów Kulowych  
Henryk & Zbigniew Nejman  
76-200 SŁUPSK ul. Słoneczna 16K  
tel/fax (059) 8-414-414; 8-414-413  
E-mail: office@autohak.com.pl  
www. autohak.com.pl

Towing hitch (without electrical set)

Class: A50-X Cat. no. X15

Designed for:

Manufacturer: DAEWOO

Model: KALOS

Type: 4 door

produced since 09.2002

Technical data:

D-value: 6,7 kN

maximum trailer weight: 1100 kg

maximum vertical cup mass: 75 kg

Approval number according to Directive 94/20/EC: e20\*94/20\*0570\*00

Foreword

This towbar is designed according to rules of safety traffic regulations. The towing hitch is a safety component and can be install only by qualified personnel. Any alteration or conversion of the towing hitch is prohibited and would lead to cancellation of design certification. Remove insulating compound and underseal from vehicle (if present) in the area of the matting surfaces of the towing hitch. The vehicle manufacturer's specifications regarding trailer load and max. vertical cup load are decisive for driving whereat values for the towing hitch cannot be exceeded.

D-value formula:

$$\frac{\text{Max trailer weight [kg]} \times \text{Max vehicle weight [kg]}}{\text{Max trailer weight [kg]} + \text{Max vehicle weight [kg]}} \times \frac{9,81}{1000} = D \text{ [kN]}$$